



# ADVANTAGE RAIL

## DRINK RAIL ADAPTER INSTALLATION GUIDE

### RECOMMENDED TOOLS

Installing the drink rail adapter should not require any additional tools than are needed for installing the railing.

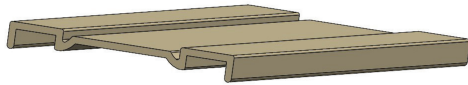

Drink Rail Adapter

### INCLUDED WITH DRINK RAIL ADAPTER

- 6' OR 8' Length of drink rail adapter
- 3/4" Flat head self drilling screws
- 3/4" Pan head hi low wood screws

### Drink Rail Brackets Not Included Please Order Separately

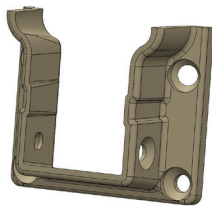

Drink Rail Bracket

## INSTRUCTIONS

For when the drink rail adapter runs continuously over the post or is spliced over the post. Typically done with 2 1/2" posts.

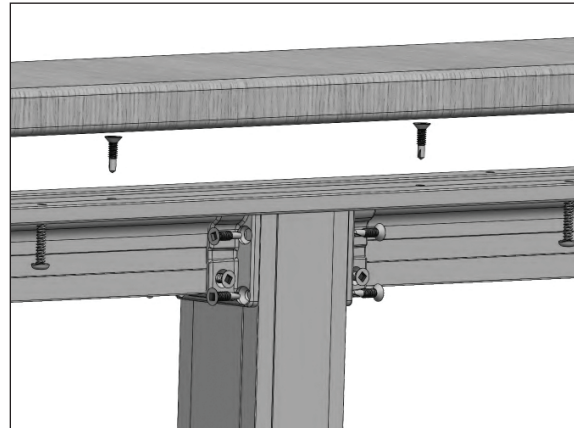

1. Cut the posts off 1/8" lower than the top rail of the section.
2. Install the section according to the section installation instructions using drink rail brackets for the top rail instead of using the standard top rail brackets.
3. Cut the drink rail adapter to length as needed.
4. Screw the drink rail adapter down to the top rail of the section using the flat head self-drilling screws in every hole in the recessed center of the drink rail adapter.
5. Install drink rail using the wood screws provided.

### Tip

You may have to assemble a section and test fit it to determine your finished rail height.

### Tip

Your cap piece must be 3 1/2" wide to cover the drink rail adapter and 1" thick so the wood screws holding it on do not come through the top of the cap piece.

OVER

## ALTERNATE INSTRUCTIONS

For when the drink rail adapter terminates into the post with the drink rail going over the post. Typically done with 3 1/2" posts.

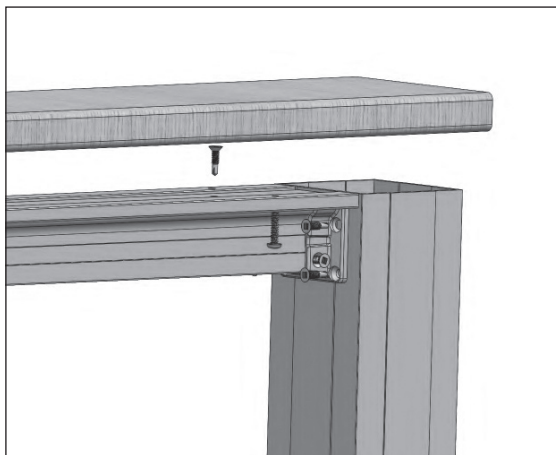

### Tip

You may have to assemble a section and test fit it to determine your finished rail height.

1. Cut the posts so that they are 3/16" higher than the top rail of the rail section.
2. Install the section according to the section installation instructions using drink rail brackets for the top rail instead of using the standard top rail brackets.
3. Cut the drink rail adapter to length as needed.
4. Screw the drink rail adapter down to the top rail of the section using the flat head self drilling screws in every hole in the recessed center of the drink rail adapter.
5. Install drink rail.

### Tip

Your cap piece must be 3 1/2" wide to cover the drink rail adapter and 1" thick so the wood screws holding it on do not come through the top of the cap piece.

- These directions are only a guide and may not address every situation.
- Always wear proper safety equipment while assembling and installing.
- The installer should obtain all required building permits and follow all installation procedures in accordance with applicable building code requirements.
- JAM Systems shall not be held liable for improper or unsafe installations.
- Applying paint, other than JAM Systems touch up paint, will void your warranty.

